



energy | innovation | sustainability | engineering | design

RULES FOR THE 2024 e-HUMAN POWERED VEHICLE CHALLENGE



Table of Contents

I. General Information.....	6
A. Objective.....	6
B. Competition Summary.....	6
C. Superiority of Rules.....	6
D. Questions and Comments About the Rules.....	6
E. Location and Competition Information.....	6
F. Definitions.....	7
G. Schedule Summary & Host Information.....	7
H. On-Site Check-in and Registration.....	8
II. Suggested Reference Material.....	9
III. General Rules of Competition.....	11
A. Number of Vehicles to Compete.....	11
B. Events of the Competition.....	11
C. Modification of Vehicles.....	11
D. Aerodynamic Devices.....	11
E. Vehicle Number and Decals.....	12
F. Fairness of Competition.....	12
G. Protests.....	12
H. Event Scoring.....	12
I. Energy Storage Devices.....	13
J. Report and Video Publication.....	13
K. Design Feedback.....	13
L. Readiness to Compete.....	13
M. Shipping.....	13
IV. Entry and Registration.....	14
A. Team Eligibility.....	14
B. Team Member Eligibility and Certification.....	14
C. Multiple Entries.....	14
D. Vehicle Design, Analysis, and Construction.....	14
E. Driver Requirement Exceptions.....	14
F. Late Vehicle Registration.....	14
G. Registration fees.....	14
H. Competition Information.....	15
I. On-Site Check-in.....	15
V. Safety.....	16
A. General.....	16
B. Performance Safety Requirements.....	16

C. Minimum Braking System Requirement.....	16
D. Rollover Protection System.....	16
E. Safety Harness.....	18
F. Vehicle Hazards.....	19
G. Battery.....	19
H. Motor.....	20
I. Electrical Safety.....	20
J. Exemptions.....	20
K. Clothing and Protective Equipment.....	21
L. Required Safety Test of Energy Storage Devices.....	21
M. Safety Certification.....	21
N. Ride Logs.....	21
O. Safety Inspection and Demonstration.....	21
P. Performance Safety Video.....	22
Q. Modifications Affecting Safety.....	22
R. Disqualification of Unsafe Vehicles.....	22
VI. Design Event.....	24
A. Objective.....	24
B. Description.....	24
C. Design Report.....	24
D. Design Report Organization.....	25
E. Design Report Content.....	25
F. Prior Work.....	29
G. Design Report Submittal.....	29
H. Late Reports.....	29
I. Design Presentation.....	29
J. Safety Video.....	30
K. Static Judging.....	30
L. Vehicle Display.....	31
M. Design Scoring.....	31
N. Design Score Penalties.....	31
O. Overall Design Scoring.....	32
VII. Drag Event.....	33
A. Objective.....	33
B. Description.....	33
C. Duration and Timing.....	33
D. Drag Course Description.....	33
E. Timing Area.....	33
F. Live Standings.....	34

G. Drivers' Meeting.....	34
H. Qualifying Race.....	34
I. Brackets and Seeding.....	34
J. Drag Race.....	34
K. Race Forfeiture.....	35
L. Start Assistance.....	35
M. Interruption and Termination.....	35
N. Scoring.....	35
O. Fouls and Penalties.....	36
P. Score Improvement for Non-qualified Teams.....	36
VIII. Endurance Event.....	37
A. Objective.....	37
B. Description.....	37
C. Electric Power Requirements.....	37
D. Endurance Course.....	37
E. Start.....	37
F. Pits.....	38
G. Start Assistance.....	38
H. General Obstacles.....	38
I. Venue Specific Challenges.....	39
J. Lap Counting Process.....	43
K. Driver/Stoker Requirements.....	43
L. Judging Area.....	43
M. Drivers' Meeting.....	43
N. Course Practice.....	44
O. Signals.....	44
P. Disabled Vehicles.....	44
Q. Fouls and Penalties.....	45
R. Interruptions.....	45
S. Termination.....	45
T. Scoring.....	46
IX. General Fouls and Penalties.....	47
A. Equipment violations.....	47
B. Safety violations.....	47
C. Drag Event false start penalty.....	47
D. Lap requirement violations.....	47
E. Illegal start assistance on course.....	47
F. Conduct violations.....	47
G. Failure to complete an obstacle.....	48

H. Damaging or loss of parcel.....	48
I. Drafting.....	48
X. Overall Scoring.....	49
XI. Announcement of Results and Awards.....	50
A. Announcement of Results.....	50
B. Presentation of Awards.....	50
C. Competition Awards.....	50
D. Other Awards.....	50
E. Review and Modification of Results.....	50
XII. Clarification and Modification of Rules.....	51
A. Clarification and Modification of the Rules.....	51
B. Questions and Comments About the Rules.....	51
XIII. Appendix 1 Design Event Score Sheet.....	52
XIV. Appendix 2: Protest Form.....	56
XV. Appendix 3: Safety Exemption Request Form.....	58
XVI. Appendix 4: Report Cover Page & Vehicle Description Form.....	59
XVII. Appendix 5: Endurance Event Lap Count Sheet.....	60

I. General Information

A. Objective

ASME's e-Human Powered Vehicle Challenge (e-HPVC) is an engineering design and innovation competition that gives students the opportunity to network and apply engineering principles through the design, fabrication, and racing of human-powered vehicles.

B. Competition Summary

ASME and the ASME e-HPVC Committee will host multiple in-person competitions.

These competitions will consist of three events: Design Event, Drag Event, and Endurance Event. Scores from each event are totaled to obtain the overall score to determine the winner. There will also be an award for best innovation at these competitions.

The locations of these competitions and associated announcements will be posted on <http://efests.asme.org>. All team captains & team members will be required to register for BOTH the competition AND the Efx they are attending through the Efx website. Any associated registration fees will be published on the Efx website. Registration dates are different for each Efx event. **Not all Efx events will have every competition available. Check that the e-HPVC is available at that event before registering.**

C. Superiority of Rules

These rules have been established by ASME's e-Human Powered Vehicle Challenge Committee. Should any conflict arise between these rules and those of the ASME, the ASME rules shall dominate. Should any conflict arise between these rules and other information regarding the ASME e-HPVC, whether generated by the ASME or any other organization, these rules shall dominate.

D. Questions and Comments About the Rules

Questions about the competitions and rules must be posted on the e-HPVC Question Forum listed below.

E. Location and Competition Information

Physical locations and digital platforms for all competitions can be found on the official e-HPVC website and E-Fest website.

Official e-HPVC Website including the rules and forms:

[https://efests.asme.org/competitions/human-powered-vehicle-challenge-\(hpvc\)](https://efests.asme.org/competitions/human-powered-vehicle-challenge-(hpvc))

e-HPVC Question Forum:

<https://groups.google.com/g/asme-hpvc>

F. *Definitions*

Competition: an individual e-HPVC hosted at a location physically (e.g. e-HPVC West)

Event: an element of the competition (e.g. Endurance Event)

Team: a group competing in the competition consisting of a vehicle and team members

Vehicle: a single entry in a competition

Individual: a single participant of a competition and likely a team member

Driver: any individual who is or will be riding in a vehicle during a competition

Competitor: an individual who is competing in a specific event at a competition (ie driver, presenter, team member)

Registration: the process to collect fees and record individual and vehicle information by ASME

Check-in: the process and act of reporting an individual's and/or vehicle's presence at a competition

Online/digital Event: an event that will be held on a digital platform rather than meeting in-person at a physical location

In-Person Event: an event that will be held at a physical location requiring individual/team presence

Traction Battery: battery or batteries used to power the motion of the vehicle

Accessory Battery: battery or batteries used to power accessories only such as lights

G. *Schedule Summary & Host Information*

The Efx website shall specify all the important dates and contact information for the relevant competition.

The following is required for participation in the competition. The required materials must be submitted as indicated in accordance with the schedule as noted. Please refer to the Efx website for exact dates, submission links, and registration instructions.

Document	Method of Submission	Date Due
Vehicle/Team Captain Registration	Every team must register online via Efx website	14 days before report deadline
Individual Registration	Every team member must register online via Efx website	14 days before report deadline
Design Report	Electronic submission via competition website	45 days before the 1st day of the in-person competition
Safety Exemption Request (Appendix 3)	Submit only if an exemption is requested and submit to Head Judge	1 week before design presentations
Design Presentation	Virtual / Zoom	2 weeks before the 1st day of the in-person competition
Individual Ride Log	Every driver must submit online via Efx competition website	Before rider check in
Rider check in		1st day of competition
Performance Safety Video	Electronic submission via Efx website	1 week before competition
Protests (Appendix 2)	Submit to Head Judge only if required	In accordance with III.G

H. On-Site Check-in and Registration

On-site check-in and registration begins on the first day (typically on Friday morning, however be sure to check the EFX event schedule for exact details) of the competition. All teams and drivers must check in (in person) before the end of the registration period to receive their vehicle numbers and wristbands (required to be eligible as a driver).

II. Suggested Reference Material

Below are reference documents helpful in HPV design and construction. If your team references any of these sources please ensure they are properly cited in your report.

Vehicle Design

1. ["The Recumbent Trike Design Primer"](https://pdfs.semanticscholar.org/5ee5/84368629fdc7ad69a3adf63da2c8e90de9f4.pdf) (Rickey Horwitz, 2010). Basic pedal-powered tricycle design considerations, online.
2. ["Engineer to Win"](https://www.amazon.com/Engineer-Win-Carroll-Smith/dp/B011MBDQOM) (Carroll Smith, 2010). Racing car design, paperback.
3. ["Race Car Vehicle Dynamics"](https://www.amazon.com/Race-Car-Vehicle-Dynamics-Premiere/dp/1560915269) (William Milliken, 1994)

Materials

1. ["Racer's Encyclopedia of Metals, Fibers & Materials"](https://www.amazon.com/Encyclopedia-Materials-Motorbooks-International-Powerpro/dp/0879389168) (Forbes Aird, 1994). Paperback.
2. ["Competition Car Composites"](https://www.amazon.com/Competition-Car-Composites-Practical-Handbook/dp/1845849051) (Simon McBeath, 2016). Composites design & fabrication handbook, hardcover.

Human Power and Bicycle

1. ["Sheldon Brown's Bicycle Technical Info"](https://www.sheldonbrown.com/) (Sheldon Brown). Bicycle design and reference guides
2. ["Design of Human Powered Vehicles"](https://www.amazon.com/Design-Human-Powered-Vehicles-Mark-Archibald/dp/0791861104) (Mark Archibald, 2016). Extensive HPV discussion, hardcover.
3. ["Bicycling Science"](https://www.amazon.com/Bicycling-Science-Press-Gordon-Wilson/dp/0262731541) (David Gordon Wilson, 2004). Broad introductory cycling resource, paperback.
4. ["The Biomechanics of Force and Power Production in Human Powered Vehicles"](https://digitalcommons.brockport.edu/cgi/viewcontent.cgi?article=1100&context=pes_facpub) (Danny Too, Gerald Landwer). Factors affecting power production via recumbent pedaling, online.
5. ["Biomechanics of Cycling"](https://www.degruyter.com/downloadpdf/i/ssr.2010.xix.issue-1-2/v10237-011-0012-0/v10237-011-0012-0.pdf) (Borut Fonda & Nejc Sarabon). Literature review of cycling biomechanics, online.
6. ["HPVC Safety Dos and Don'ts"](https://community.asme.org/hpvc/w/wiki/13014.educational-resources.aspx#Safety-Dos-Donts) (Mark Archibald, 2016). HPV safety best practices.
7. ["Lords of the Chainring"](https://www.amazon.com/Lords-Chainring-William-Patterson-ebook/dp/B006W4170G) (William Patterson, 2012). Technical theory of the handling qualities of bicycles and motorcycles. Basis of a university course on single track vehicle design.

Electric Bicycle Guidelines:

1. Electric bike Class 1-3:
<https://www.bosch-ebike.com/us/everything-about-the-ebike/stories/three-class-ebike-system>
2. E-bike general tips: <https://www.ebikeschool.com/torque-arm-need-one/>

Free Design and Simulation Tools

1. <https://altairuniversity.com/free-altair-student-edition/>
2. <https://www.autodesk.com/education/edu-software/overview?sorting=featured&page=1>
3. <https://www.ansys.com/academic/students>
4. <https://www.circuitlab.com/>
5. <https://ebikes.ca/tools/simulator.html>

E-bike vendors (not an endorsement, just a starting point)

1. <https://ebikes.ca/shop/ready-to-roll-kits/rear-rtr.html>
2. <https://em3ev.com/>
3. <https://www.goldenmotor.com/>

If you have any suggestions for additional reference materials please post it on the e-HPVC Question Forum

III. General Rules of Competition

A. *Number of Vehicles to Compete*

There may be a cap on the maximum number of teams at any competition. If so, it will be listed on the EFX website at least 90 days before the competition. There is no requirement for a minimum number of vehicles. However, should the number of vehicles entered be more than one but less than four, the number of awards granted for overall placement in that competition shall be one less than the number of competing vehicles.

To be eligible for the overall 1st, 2nd, or 3rd place winner, a vehicle must compete and score in all events.

B. *Events of the Competition*

Teams will develop innovative pedal electric vehicles. The competition shall comprise of the following events:

- Design Event: Teams are scored on their application of sound engineering principles and practices toward a vehicle design. This event includes a written report, a technical presentation, performance safety video, and static judging of their e-HPV.
- Drag Event: Teams are scored on the speed of their vehicles in a head-to-head drag race from a standing start.
- Endurance Event: Teams are scored on speed, practicality, performance, and reliability of their vehicles in a road race format with urban transportation obstacles and challenges.

C. *Modification of Vehicles*

Modifications to the vehicle are allowed between events, as long as safety is not compromised. Vehicles must retain their main frame and general drivetrain configuration. Any vehicle deemed to have undergone changes in excess of this allowance will be permitted to compete if it does not present a safety risk; however, any scores achieved will not be credited to the original entry. Vehicles in which the basis of design involves changes to the main frame or drive train configuration for various racing events must submit a request for a waiver prior to the report due date.

D. *Aerodynamic Devices*

Vehicles may include components, devices, or systems engineered specifically to reduce aerodynamic drag. Front fairings, tail sections, full fairings, and other such devices are encouraged. The effectiveness of aerodynamic devices must be substantiated in the design report in order to receive credit for the design scores regarding aerodynamics.

Make-shift devices which are unrepresentative of the design, are crudely crafted, and/or present a clear safety concern will be prohibited and must be removed prior to racing unless previously granted a waiver by the Head Judge. Fairing configurations may be changed between events in accordance with Section III.C provided that all safety requirements, including the seat belt and Rollover Protection System (RPS) rules, are not compromised by the change of configuration.

E. *Vehicle Number and Decals*

The Head Judge will assign each vehicle a number. The number "1" will be granted to the overall winner from the prior year's competition. All other numbers will be assigned. At their discretion, the Head Judge may consider requests for specific vehicle numbers, but number zero or numbers greater than double-digit numbers will not be allowed. Requests can be made by sending an email to hpvc@asme.org

Decals: ASME will provide two adhesive decals to each team during the on-site registration process. Each decal will display the assigned vehicle number as well as the e-HPVC logo. Each vehicle shall provide sufficient space on either side for these stickers. This space may include fairings, cargo containers, or surfaces specially designed for this purpose. The decals shall be no larger than 35 cm wide x 30 cm high. If one or both of the e-HPVC decals are lost, obscured, or difficult to see from either side of the vehicle, the vehicle shall be removed from the competition until they are restored. If a vehicle number is obscured during an endurance race, any laps run without a visible number will not be counted.

School Name: All vehicles should display their school name or initials on each side of the vehicle in characters at least 10 cm high in a color that contrasts with the background.

F. *Fairness of Competition*

All participating teams will be assured an equal opportunity and a fair competition. Any participating team that, in the reasoned opinion of the judges, seeks to exert an unfair advantage over other competitors will be subject to a penalty in performance points or disqualification from the competition.

G. *Protests*

Protests must be announced to a member of the judging staff either at the time of the incident or within a 15 minute period following the announcement of the results of the event. Following the announcement of the intent to protest, a written protest (see Appendix 2) must be presented within 30 minutes unless otherwise allowed by the Head Judge. Oral protests will not be recognized.

Protests must be specific in nature and must include a factual account of the event being protested and the specific rules infraction, or the perceived error in the scoring of an event. Protests will be examined and resolved by the judges at their earliest convenience. Their decision will be communicated through email and will be final and without further appeal.

H. *Event Scoring*

Scoring for each event will be based on a points system. The team with the most points in an event wins that event. The team with the highest overall score from various events in the competition will become the overall winner of the competition.

I. *Energy Storage Devices*

Vehicles may employ the use of electric energy storage devices but combustion engines are excluded from the competition.

Previous competitions have allowed electric storage only if it was generated during the event (e.g. by pedaling and regenerative braking). In this competition, starting with stored energy is allowed and encouraged. See Section V.G

J. *Report and Video Publication*

After the completion of the annual competitions, all reports and submitted videos and/or presentations may be published on a shared website.

If a team does not want their report and/or video/presentation posted publicly, the team must submit a request, in writing, to the Head Judge no later than the submission deadline. The request must convincingly outline the grounds (such as active NDAs, or submission for intellectual property) for which the request is being made, and teams must be prepared to present an alternative submission omitting any specific sections in question. Requests will be granted or denied by the judges, and their decision will be final and without appeal.

K. *Design Feedback*

In an effort to help teams learn from their experience, the competition judges will record feedback on each team's performance in the Design Event.

During the evaluation of the reports and presentations, the judges will take note of specific areas where teams may be able to improve their scores. Judges will be looking for things like areas that may be missing key details, where teams missed the mark with information provided or just generally in what areas the team can improve the most. Feedback provided will be constructive and actionable so that teams will walk away with a better understanding of the scores they received and how they can improve their skills further.

Written feedback will be sent to teams that request it via email to hpvc@asme.org

L. *Readiness to Compete*

Teams must show up ready to compete and repair facilities will only be provided if the host offers it. The host is not responsible for assistance with vehicle repairs. All vehicles must arrive at the competition ready to ride and pass the safety inspection.

M. *Shipping*

It is the responsibility of the participants to comply with transportation regulations associated with the shipment of dangerous goods material. Teams are required to understand the consequences of non-compliance with such regulations which may include non-participation in the event due to delayed shipment.

IV. Entry and Registration

A. Team Eligibility

Entry in the e-Human Powered Vehicle Challenge is open to teams from any college or university in the world, including community colleges. Community college students have the option to join competition teams at nearby universities.

B. Team Member Eligibility and Certification

All members of the respective school's team must be enrolled as students in any program of study at that school. Any individual that is currently a full-time student, enrolled for the next upcoming semester/quarter, or has been enrolled for the previous semester/quarter, but graduated no earlier than six months prior to the competition date, is eligible to fully participate in the ASME e-HPVC. The team captain must be from the engineering department of the college or university.

All competitors must complete registration for the EFX event and e-HPVC competition they plan to compete in. A competitor may only register and compete on one team for each competition.

All the drivers must submit a ride log before the competition.

C. Multiple Entries

Multiple teams from a single university are allowed provided that they have different team members.

D. Vehicle Design, Analysis, and Construction

The research, analysis, and design of all vehicles entered by a school must be performed solely by current eligible team members. All student team members shall be listed on the team's certified roster. Construction of the vehicle may include the assistance of outside vendors where the required capabilities exceed those available at the school.

E. Driver Requirement Exceptions

If a participating school's roster cannot support at least one complete team, that school may request the voluntary participation of one or more drivers from volunteers in attendance provided that the volunteer 1) meets all eligibility requirements from and 2) will not participate in the same event for any other team. The requester must submit a written request for a waiver of the rules for this purpose to the Head Judge for approval prior to the start of the applicable event. Scores derived in this manner will be credited to the requester.

F. Late Vehicle Registration

At its sole discretion, ASME may consider late vehicle registration after the entry date.

G. Registration fees

Any associated registration fees will be published on the EFX website.

H. Competition Information

The following information, or a URL for a website that contains this information, shall be provided to each team:

- Vehicle number
- List of deadlines
- Submission forms for the report, ride log, and video submissions
- Schedule of events
- Schedule of presentations
- Endurance venue specific challenge

I. On-Site Check-in

All competitors must check in on-site at the registration desk before participating in the competition.

During the on-site check-in process teams may:

- Receive identification for each driver (arm stamp, wrist bracelet, etc)
- Receive two decals to display their assigned vehicle numbers
- Receive a final schedule, including times, locations, and other event information

V. Safety

A. General

The safety of participants, spectators, and the general public will override all other considerations during the competition. The judges will consider the safety features of the courses, as well as those of the competing vehicles, in permitting each event of the competition to begin or continue. Any event of the competition may be delayed, terminated prematurely, or canceled if the Head Judge, in consultation with ASME staff and the competition judges, determines that such action is necessary in the interest of safety.

B. Performance Safety Requirements

Each vehicle must demonstrate that it can come to a stop from a speed of 25 km/hr in a distance of 6.0 m (19.7 ft), can turn within an 8.0 m radius (26.2 ft), and demonstrate stability by traveling for 30 m (98.4 ft) in a straight line at a speed of 5 to 8 km/hr (fast-paced walking speed).

C. Minimum Braking System Requirement

At a minimum each vehicle must have a braking system with properly designed brakes on the frontmost wheel of the vehicle. If multiple forward wheels are employed (such as in a tadpole trike or quad bicycle design) each wheel must have its own brake. Simply put, vehicles must at least have front brakes.

Even though teams may employ front brakes as outlined here, teams are still responsible to conduct adequate testing to ensure that the vehicle can pass the stopping performance test outlined in the performance safety requirements. Teams must also ensure that the braking system is capable of stopping the vehicle when using electric propulsion.

D. Rollover Protection System

All vehicles must include a rollover protection system (RPS) that protects all drivers in the vehicle in the event of an incident unless the RPS makes the vehicle less safe. In that case, a safety exemption must be requested.

Functionally, the RPS must:

- Absorb sufficient energy in a severe accident to minimize the risk of injury
- Prevent significant body contact with the ground in the event of a fall (vehicle moves from upright to resting on its side) or rollover (vehicle moves from upright to an inverted position)

The RPS must allow for a load path supporting the driver and retaining them from being ejected from the HPV in the event of a crash. This load path will be defined from the ground (impact point), to the outside of the vehicle body, through the structural RPS, through the safety harness, to the driver's body (center of gravity). A thorough RPS design includes the structural fortitude of not only the roll bar/frame but also a rigidly mounted and structurally sound seat and properly affixed safety harness. In the RPS analysis teams must document the load path from driver to ground to receive full points.

In order to demonstrate the effectiveness of the RPS in protecting body contact from the ground teams may be required, during safety check, to lay their vehicle on its side as well as invert it fully with the largest driver inside. Once laying on its side and inverted the driver must not make

contact with the ground and if safety is compromised vehicle modifications will be required or the vehicle will not be allowed to race.

The RPS must be primarily a continuous hoop or truss, capable of withstanding all forces throughout a plausible rollover crash sequence, including reasonably likely forces not described in the load cases required for analysis & testing. Discrete cantilevered structural members oriented in directions of defined load cases are not acceptable. In order to participate in the competition, all RPS structural components (including the continuous hoop) must be physically tested or analyzed according to the top & side load requirements described below, and the results need to be presented in the design report and the presentation.

The RPS shall meet the top and side load requirements described below.

1. RPS Load Cases

The RPS system shall be evaluated based on two specific load cases – a top load representing an accident involving an inverted vehicle and a side load representing a vehicle fallen on its side. In all cases the applied load shall be reacted by constraints at the safety harness attachment points; simulating the reaction force exerted by the driver in a crash.

- a) Top Load: A load of 2670 N per driver/stoker shall be applied to the top of the roll bar(s), directed downward and aft (towards the rear of the vehicle) at an angle of 12° from the vertical, and the reactant force must be applied to the seat belt, seat, or roll bar attachment point and not the bottom of the roll bar (unless the bottom is the attachment point). Note that there may be one roll bar for the driver and another roll bar for the stoker which will result in each RPS having an applied load of 2670 N, or the driver and stoker can both be protected by a single roll bar which will result in the RPS having an applied load of 5340 N.

The roll bar is acceptable if 1) there is no indication of permanent deformation, fracture, or delamination on either the roll bar or the vehicle frame, 2) the maximum elastic deformation is less than 5.1 cm and shall not deform such that contact with the driver's helmet, head or body will occur.

- b) Side Load: A load of 1330 N per driver/stoker shall be applied horizontally to the side of the roll bar at shoulder height, and the reactant force must be applied to the seat belt, seat, or roll bar attachment point and not the other side of the roll bar. Note that there may be one roll bar for the driver and another roll bar for the stoker which will result in each RPS having an applied load of 1330 N, or the driver and stoker can both be protected by a single roll bar which will result in the RPS having an applied load of 2670 N.

The roll bar is acceptable if 1) there is no indication of permanent deformation, fracture or delamination on either the roll bar or the vehicle frame, 2) the maximum elastic deformation is less than 3.8 cm and shall not deform such that contact with the driver's helmet, head occurs.

2. RPS Attachment

The RPS must be structurally attached and braced to the vehicle frame or fairing and, with the vehicle in the upright position, must extend above the helmeted head(s) of the driver(s) such that no part of any driver will touch the ground in a rollover or fall over condition. The RPS may be incorporated into the fairing, providing that part of the fairing is used in all events. Teams must demonstrate that the RPS meets both functional requirements and loading requirements. See Figure 1

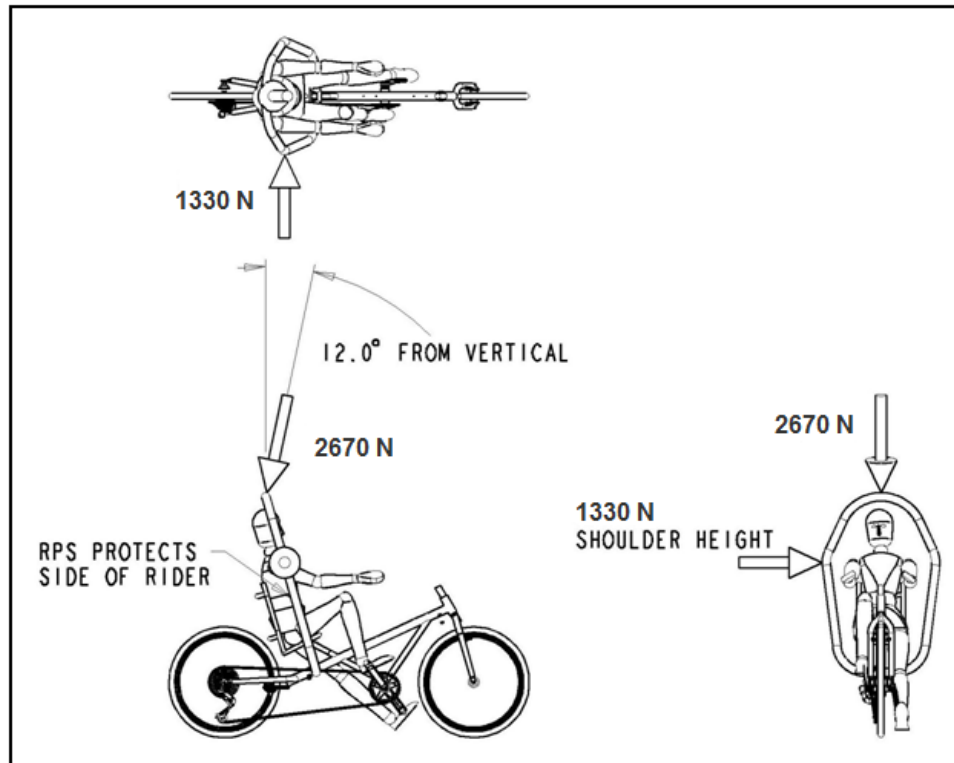

Figure 1: Example of Proper RPS Design and Side and Top Load Case Applications (Note: Loads shown should not be applied concurrently in analysis and/or testing. Reaction loads should be applied at safety harness attachment points)

E. Safety Harness

All drivers of all vehicles must be secured to their vehicle by **safety harnesses with lap and shoulder belts** (also known as 4 or 5 point safety harnesses) at all times that the vehicle is in motion, unless the safety harness makes the vehicle less safe. In that case, an exemption must be requested per Section V.J. Lap belts or shoulder belts alone will not be sufficient and will require upgrading prior to racing. Commercially available harnesses designed for automotive, aviation or racing applications will generally be accepted without test data for the straps and buckles. Test data for attachment points may still be required at the time of the safety inspection.

Harnesses should be adjusted as firmly as possible, consistent with comfort, to provide the protection for which they have been designed. The safety harness must prevent any upward or forward motion of the driver's torso. Any slack in the harness must be adjusted by using the seat belt length adjuster. The safety harness must always be worn tight and fastened to prevent the

driver from having free movement when the vehicle is in motion. Loose safety harness while riding the vehicle will be subjected to penalty for safety violation.

The safety harnesses must be attached to the RPS or a structural member in the RPS and may not be attached to the seat unless it is structurally integrated into the RPS.

3. Custom Fabricated Harnesses

If the harness is custom fabricated by the team or a commercial entity not in the business of producing harnesses or webbing products designed for use in life supporting applications (i.e. climbing, racing, automotive), significant test data will be required, as defined below.

- Hand stitching of webbing is not acceptable under any situation. Machine stitching will be acceptable with supporting test data.
- Webbing connections secured with a properly tied water knot will be accepted without test data.
- The minimum acceptable width for harness webbing is 25mm.

4. Testing requirements for non-commercially produced harnesses

- Tensile test samples of a stitched joint must be prepared in an identical manner to the intended production method including: Base webbing material, thread, stitching pattern and quantity.
- Tensile tests performed on a minimum of 5 samples must show a 95% statistical confidence of an ultimate strength in excess of 3340 N.

5. Testing requirements for off application buckles

- Off application is defined as a buckle designed for anything other than a life supporting applications (automotive, aviation, climbing, etc.). Other buckles designed for life supporting applications will be accepted without testing documentation.
- Plastic buckles of any type are not permitted.
- Tensile tests performed on a minimum of 5 samples must show a 95% statistical confidence of an ultimate strength in excess of 3340 N.

All drivers must demonstrate the ability to exit the HPV in less than 15 seconds during safety inspection. This shall be evaluated under no external assistance.

F. *Vehicle Hazards*

All surfaces of the vehicle—both on the exterior and in the interior in the region of the driver(s) and in the access area—must be free from sharp edges and protrusions, open tube ends, screws protruding more than three threads, and other hazards. All drivetrain components, steering components, and wheels must be fitted with appropriate guards if within reach of the driver and must be designed and constructed so that they will not injure the driver in the event of an accident. All fasteners must be secured with a thread locking method (e.g., lock-tite, nylon locknuts, double-nut, castle nut).

G. *Battery*

Each vehicle is limited to one traction battery and must have a maximum capacity of 500 Wh. This battery must not be self-built and must have a battery management system (BMS) to control and protect the battery. Such a BMS shall have short circuit, over current and over temperature protection..

Vehicles may have additional accessory batteries used to power other electrical systems such as lights, telemetry, etc. These batteries must be on separate electrical systems from the traction battery and must not provide any propulsion to the vehicle.

H. *Motor*

Each vehicle is limited to one electrical motor with the associated control unit. The electric motor can be purchased or self-built for the competition and must be rated for a maximum of 500W.

I. *Electrical Safety*

Competitors must take note of the following safety measures associated with electrical components:

- Lead acid batteries of any type are prohibited.
- Maximum system voltage is limited to 50V.
- All electrical equipment used must be properly fused or protected by the battery BMS.
- Electrical cables must be in good condition and appropriately sized for the intended application. Wiring must be neatly secured and away from moving parts.
- All electrical drive system components such as battery, motor controller and motor must be securely mounted within the vehicle and should be easily accessible for inspection.
- The traction battery must be isolated from the rider using a rigid bulkhead. This bulkhead serves to protect the rider in case of battery fires or battery release incidents. Any gaps between the rider's compartment and battery must be sealed.
- The traction battery must be securely attached to the vehicle so that it does not separate from the vehicle during use or in a crash. Judges will have wide discretion here, generally attachment with tape, elastic cords, zip ties or small velcro straps will not be allowed.
- Teams shall use appropriate equipment to mitigate and control battery fires. Such equipment could be battery charging bags that are designed to contain fires and fireproof blankets.
- All vehicles must have an external emergency shutdown switch that isolates the battery from the other electrical components when actuated. This emergency shutdown switch must be rated for the appropriate voltage and current of the vehicle electrical system. The emergency shutdown switch must be positioned on the exterior of the vehicle, clearly indicated, and easily actuated.
- During the safety inspection the team must be prepared to discuss the safety of the storage device, especially during a high-speed incident. Teams whose vehicles present an unacceptable risk in the perception of the judges will not be allowed to utilize the energy storage device in the competition.

J. *Exemptions*

Any team may request an exemption from rules Section V.D and/or Section V.E using the Safety Exemption Request Form in the appendix. The request must be based on the safety of the driver or general public and must be submitted with the design report. The request must convincingly argue that safety is enhanced by omitting the safety harness and/or the RPS. Waivers will generally not be granted for fully faired vehicles, recumbent vehicles, or vehicles with three wheels. Requests for waivers will be granted or denied by the judging committee, and their decision will be final and without appeal. Without a waiver granted by the competition judges, teams without the RPS and/or safety harness will not be able to compete in any racing event.

K. *Clothing and Protective Equipment*

All participants must wear fully enclosed shoes (entire foot is covered), appropriate clothing and properly fitting helmets with fastened straps that meet CPSC Safety Standard for bicycle helmets (16 CFR Part 1203) or equivalent while:

- Warming up or orienting themselves on any event course
- Riding in all events and safety check
- Riding any competing vehicle or other human powered vehicle on or in close proximity to an event course.

Note that this requirement applies to all participants riding any HPV or bicycle, including personal vehicles. The helmets must be worn properly. Loosely worn helmets will be subjected to a safety violation penalty.

L. *Required Safety Test of Energy Storage Devices*

Vehicles that utilize energy storage devices shall specifically address the safety of the device or system in the design report and during the safety inspection. In particular, safety in the event of a high-speed accident shall be addressed. Teams whose vehicles present an unacceptable risk in the perception of the judges will not be allowed to utilize the energy storage device in the competition.

M. *Safety Certification*

Participating teams must certify (e-HPVC Safety Certification) that:

- The design and construction of their respective vehicles have been carried out with due consideration of occupant and bystander safety, especially with the introduction of electrical components.
- Team members have been appropriately trained regarding the handling of electrical components (such as batteries) and understand safety measures in case of any hazards/accidents.
- The specified safety tests will have been completed before arrival at the competition.

N. *Ride Logs*

All drivers must have a minimum of 30 minutes riding experience in their vehicle prior to the competition. The form must clearly indicate the driver's name, date, duration in hours and minutes, and location for each ride or vehicle test. Each team is encouraged to submit a ride log through an online form prior to the competition. The ride log must be submitted for each driver before the event they are to compete in. Failure to submit the ride log will result in the driver being not allowed to compete in any of the events.

O. *Safety Inspection and Demonstration*

A competition official shall oversee tests of each vehicle's ability to meet the braking, turning, and forward motion requirements. Each vehicle shall be visually inspected by the judges to ensure that no hazards exist that are likely to cause harm to the driver, passengers, competitors, or spectators. Potential hazards include but are not limited to defects or play in the steering system, electrical safety, sharp edges, protruding bolts, open tube ends, and pinch points. In addition, the vehicle must provide the driver with a forward-facing field of view of at least 180° wide.

The rollover protection system must appear substantial and correctly installed. The tallest driver on the team must sit in the vehicle with the safety harness locked and demonstrate the roll bar assembly extends beyond the driver's helmeted head and shoulders.

The safety check will take place during the scheduled safety inspection time block. No vehicle will be allowed to participate in any race unless it has successfully completed the safety check. It is expected that teams evaluate the safety of their vehicles before they arrive for the safety inspection. This includes the mitigation of all safety hazards as well as performance safety requirements. All teams will be granted at least one attempt at a successful safety evaluation, but any team that fails the safety inspection may make a request to the safety judge for a re-inspection at a later time. Such re-inspection will be granted at the sole discretion of the safety judge based on available time. If the re-inspection occurs after the designated inspection time block for that team, the team may be assessed a design score penalty up to 10%. Note: if time does not permit a team to complete their safety inspection they will not be allowed to race until a re-inspection time has been scheduled and the inspection has been completed successfully.

P. *Performance Safety Video*

One week before the race, teams will submit a short video (maximum 2 minutes) showing their HPVs completing the three performance safety requirement tests and electrical safety. This video can be very brief as it must only show the vehicle completing the tests, or if the tests cannot be completed successfully, teams must briefly explain how they will modify their vehicles to pass by the date of the race. To conduct the tests a crude test setup and a visual estimate for vehicle speed will be acceptable. A link will be posted on the EFX website to submit the video file.

Q. *Modifications Affecting Safety*

Modifications to vehicles between events of the competition must not compromise the safety of the vehicle. If the competition officials determine that any modification has reduced the safety of the design to an unacceptable level, the vehicle will be disqualified from the affected event of the competition.

R. *Disqualification of Unsafe Vehicles*

The competition officials reserve the right to remove from the competition any vehicle that is judged to be unsafe by any metric. Riders must always be in control of their vehicles. Loss of control of an HPV such that it poses an immediate safety risk to the rider, spectators, or any other person(s) may constitute immediate suspension barring said vehicle or specific riders from further racing of the HPV in that event and subsequent events. This determination will be made by the Head Judge, in consultation with the Judging Team and ASME staff, and will be final. This includes consideration of a vehicle's perceived performance under prevailing weather conditions.

Petitions for a disqualified vehicle or rider to be reinstated into the competition can be made on the grounds that safety concerns have been corrected, or on a rider-by-rider qualification that will be conducted to prove that he or she can handle the vehicle to the satisfaction of the judging team. The considerations to reinstate removed vehicles or riders will be made by the judging team if sufficient time is available and will not be made if it impedes the function of the judging staff during an ongoing event. There is no guarantee that a disqualified vehicle or rider will be reinstated and all decisions by the judging team will be final.

VI. Design Event

A. Objective

To demonstrate the effective application of established principles and practices of design engineering to the development of the team's vehicle.

B. Description

The Design Event includes four parts:

1. Design report submitted in advance of the competition
2. Safety video submitted to the Judging Team
3. Design presentation to the Judging Team
4. Safety and static inspection by Judging Team

Failure to submit a design report will result in the non-evaluation of a team's design presentation. If a team fails to complete any part of the Design Event, their vehicle will be judged as a non-participant. This condition will not affect the vehicle's participation in the other events, provided that the vehicle successfully completes the safety inspection.

C. Design Report

The report should concisely describe the vehicle design and document the design, analysis, and testing processes and results. The report should have the character of a professional engineering report and should be organized as described in Section VI.D.

Reports should emphasize clarity both in presentation and in the statement of results and conclusions. Photographs and drawings are encouraged where beneficial in documenting unique features of the design.

The design report must clearly display the vehicle number on the cover page.

Design reports shall use 12-point Calibri font, single line spacing within paragraphs, and double-line spacing between paragraphs. Major headers shall be 14-point Calibri Bold, left justified. Margins shall be 1 inch on top, bottom, left, and right. All figures and tables shall include a caption in 10 point Calibri italic font. Avoid watermarks and graphics that obscure text legibility.

Report writers should note that bulk is not a desirable feature; therefore, reports have a 20 page maximum limit. The required cover page, 3-view drawing, abstract, and references are not included in the page count. Penalties will be levied for exceeding the page limit. Judges will not consider any page beyond the 20th, and every page after the 20th will result in a 3% penalty to the report.

The judges' score sheet is included in the appendix of these rules. Teams are strongly encouraged to carefully read the score sheet prior to writing the design report.

Teams are expected to comply with ASME's Code of Ethics in the creation of their reports.

D. *Design Report Organization*

The design report shall be organized as follows:

- | | | |
|-------|---|--|
| I. | Report Cover Page & Vehicle Description Form | No page number |
| II. | Title Page | No page number |
| III. | 3-View Drawing of Vehicle | No page number |
| IV. | Abstract | Page i |
| V. | Table of Contents | Page ii |
| VI. | Design | Page 1, First page that counts towards limit. |
| | a. Objective | |
| | b. Background | |
| | c. Prior Work | |
| | d. Design Specifications | |
| | e. Concept Development and Selection Methods | |
| | f. Innovation (if any) | |
| VII. | Analysis | |
| | a. RPS Analyses | |
| | b. Structural Analyses | |
| | c. Aerodynamic Analyses | |
| | d. Electrical Analyses | |
| | e. Other Analyses | |
| VIII. | Testing | |
| | a. Developmental Testing | |
| IX. | Conclusion | |
| | a. Comparison – Design goals, analysis, and testing | |
| | b. Evaluation | |
| | c. Recommendations | Last numbered page, Last page that counts towards limit |
| X. | References | |

E. *Design Report Content*

Content of each section should be in accordance with the design report score sheet in the appendix of these rules.

1. Report Cover Page & Vehicle Description Form

The first page should be the completed Report Cover Page & Vehicle Description Form, available in the appendix of these rules.

2. Title Page

The title page should include the report title, vehicle number (assigned by ASME), names of team members including contact information for two designated team members, and the name and contact information of the faculty advisor.

3. 3-View Drawing of Vehicle

Include a drawing of the complete vehicle with at least front, top, and side projections. Key dimensions such as wheelbase, track, overall length, and overall width should be included. Drawings to follow ASME Y14.5 and related standards such as ASME Y14.24 and ASME Y14.3

4. Abstract

The abstract should give a clear summary of the objectives, scope, and results of the vehicle design. It should be limited to no more than 300 words.

5. Design

The Design section should include an overall description of the vehicle with appropriate background information, design objectives, design criteria, and design alternatives that were considered. It should clearly demonstrate that established design methodologies, including structured design methods and engineering principles, were effectively used during the vehicle design process.

Design sub-sections include:

a) Design Objectives

Clearly state the objectives and design mission of the vehicle

b) Background Research

Include supporting research and review of prior art. Provide background information to justify your objectives, mission, design approaches, and design concepts. Background research should include specific information found/used to aid in design and development of the e-HPVC, but should not include your team's general competition history. Appropriate background research can include information found on HPV development, aerodynamics, HPV standards (such as ISO or Federal), competitive vehicles, etc. Cite references as appropriate.

c) Prior Work

Clearly document any design, fabrication, or testing that was not completed in the current academic year. If teams reuse work from previous years and it is not listed here, then teams will be assessed a penalty for reusing content.

d) Organizational Timeline

Include an organizational timeline or Gantt chart showing project scheduling and completion.

e) Design Criteria

Provide the design specifications for the vehicle. Tables and bullets may be used. Provide rationale or justification for the specifications as appropriate. Use document methods such as QFD to develop the specifications.

f) Concept Development and Selection Methods

Document the use of established concept development and selection tools such as the Pugh's Concept Selection Technique, etc.

g) Description

Describe the final vehicle design, making generous use of drawings and figures. Describe how the vehicle can be practically used, what environmental conditions (weather, etc.) were addressed, and how components and systems were selected or designed to meet the stated objectives. Also showcase the energy diagram and electrical schematic with

appropriate labels indicating the battery, motor, motor controller, wiring, and vehicle cut-off mechanism. This schematic should include component values such as voltage, etc.

h) Innovation

Describe aspects of the vehicle design that are particularly innovative (if any).

6. Analysis

The analysis section summarizes the engineering evaluation of the vehicle's performance and structural viability as related to the design criteria outlined in the description. **For each analysis documented, the objective, modeling method & assumptions, results, and conclusions should be clearly indicated.** Conclusions should describe how the results were used to improve the vehicle, i.e. what changes were made as a result of the analysis.

Each sub-section should include a table summarizing all analyses completed in that section. The summary should include objectives, methods, and results. In addition, provide selected examples of specific analyses in sufficient depth to allow judges to evaluate the technical correctness of the analysis.

Analysis sub-sections include:

a) RPS Analysis

Document the structural analysis of the rollover and side protection system. This section must convincingly demonstrate that the RPS is fully compliant with Section V.D of these rules in order to obtain full points.

b) Structural Analysis

Document structural analyses conducted on the frame or mechanical components. Specify objectives, load cases, methods, and results. FEA is an appropriate tool, but not the only tool, used for structural analyses.

c) Aerodynamic Analysis

Document aerodynamic analyses, including drag estimates, conducted on fairings, aerodynamic devices, or other components. CFD is an appropriate tool for aerodynamic analyses.

d) Electrical Analysis

Document electrical analyses, including analysis of provided safety features (such as external emergency shutdown mechanism), impact on performance and usage of hybrid vehicle as a means of transport.

e) Other Analysis

Document other analyses conducted during the design process, including power/speed modeling, vehicle handling, stability, steering, suspension kinematics & dynamics, optimizations, etc.

7. Testing

The testing section documents physical tests and/or experiments conducted to develop or verify the design. For each test, the objectives, methods, results, statistical analysis of data, conclusions, design modifications, and comparisons to product design specifications should be clearly described to acquire full points. Test results should be compared with design specifications and analytical predictions and should document design changes/validations driven by said results. Sufficient examples should be included to demonstrate the extent to which physical testing was used during the design process. This section should include the following sub-section:

Developmental Testing Document physical testing conducted to develop or optimize the vehicle design. This testing is usually done early in the design phase to aid in the design process. Include objective, methods, results, and conclusions. Examples of developmental testing include, but are not limited to testing weld quality, composite materials, RPS mock-up, and prototype sub systems.

8. Conclusions

Demonstrate that the design team completed a substantive evaluation of the vehicle design. This section should include the following subsections:

Comparison: Use a table to compare the vehicle design specifications with analytical performance predictions and experimental results. Were design objectives met?

Evaluation: Describe how the final vehicle was evaluated with respect to the objectives and design specifications.

Recommendations: Document any recommendations for future work on the vehicle, including but not limited to modifications and improvements.

9. References

Citations must be provided for all non-original content. Citations should be formatted in the IEEE citation style or a similar scientific citation style. Doesn't count towards the page limit

F. *Prior Work*

Design credit will only be given for work done during the current academic year.

The report should clearly indicate if the documented design work is for a new vehicle design or improvements to a previous design. To be considered a new design, the vehicle must be substantially different from previous or additional entries (in the event a school is submitting multiple entries into a single competition) by that team or school. A substantially different vehicle has a significantly different objective or has a significantly different design solution. It is acceptable to advance and refine the design of an existing vehicle, but the new developments must be clearly differentiated from prior work.

In the event that the design is not a completely new design, the report must clearly identify which features of the design are new and what new analyses, tests, etc., were performed to verify the design changes. Scoring is based solely on the current year's work and design points will not be awarded for design work done in previous academic years.

Unoriginal content, including content generated from other teams or previous years and not cited, may be assessed a penalty for plagiarism.

G. *Design Report Submittal*

The design report must be submitted electronically as a PDF by the report's due date. See the EFX competition website for dates and instructions specific to each competition.

H. *Late Reports*

A penalty will be issued for each day the design report is submitted past the published deadline.

I. *Design Presentation*

1. Objective

The design presentation gives teams an opportunity to present the design methodologies, including structured design methods, innovation, and engineering principles which were effectively used during the vehicle design process. The presentation should focus on the considered design alternatives, design challenges, and solutions adopted by the team. The design presentation also gives teams an opportunity to provide RPS & performance testing results and any updates following the design report.

2. Format

The presentation will be hosted on a digital platform in live format in advance of the in-person competition. The schedule of presentations will be shared one week before the presentation date. Other teams are encouraged to watch as many presentations as they wish.

3. Time Limit

Design presentations will have a maximum time limit of 12 minutes followed by a maximum of 3 minutes of questions from the judges.

4. Content & Scoring

Presentations will be scored by the same judges who scored the submitted design reports.

5. Supporting Material and Visuals

Supporting material is encouraged; acceptable media includes posters, photographs, charts and other visuals. Live videos, photographs, data, and other digital visual media will be allowed.

J. *Safety Video*

1. Overview

Teams must submit a short safety video showing their vehicle completing the performance safety requirement tests and their safety analysis and features. Videos must be less than 2 minutes long.

2. Performance Safety Tests

The portion of the video featuring the performance safety tests can be very brief as it must only show the vehicle completing the tests, or if the tests cannot be completed successfully, teams must briefly explain how they will modify their vehicles to pass by the date of on-site safety inspection. To conduct the tests a crude test setup and a visual estimate for vehicle speed will be acceptable.

3. Safety

Teams are to conduct an analysis of potential hazards and how the team addressed safety of the 1) vehicle occupants, 2) bystanders and 3) vehicle builders during the construction of the vehicle (i.e. shop safety).

Features, components and systems designed to mitigate hazards should be described. Of particular interest is how established engineering principles were used to design safety systems. Teams must also address how their design protects the rider's head and appendages such that they do not contact the ground in the event of a crash where the vehicle falls over or inverts.

Teams are required to have at least one additional safety feature of their choosing which improves the safety of their specific vehicle design/configuration. The need, quality and perceived performance of the execution of this safety feature will be evaluated to determine points awarded.

At the time of safety inspection teams must have a functioning bell/horn, headlight, taillight, side reflectors and rearview mirror(s) in order to achieve points for safety accessories.

4. Video Submission

The safety video must be submitted electronically via a link on the competition website. Video files must be less than 500MB and in .mp4 format. See the applicable EFX website for the submission deadline and submission form.

K. *Static Judging*

Prior to the start of the safety inspection, vehicles will be statically inspected for:

- Physical characteristics
- Design features
- Safety features
- Consistency with report
- Safety
- Aesthetics

L. *Vehicle Display*

A designated time block will be set aside for a required public static display of the competing vehicles. At least one team member must be present with the vehicle at all times. During the static display time, it is expected that other participants, spectators, and the competition officials will tour the display area. The judges may also review the display and inspect the design features of any vehicles for which a design report was not received.

M. *Design Scoring*

Design scoring is based on the extent to which established engineering design principles were applied in the design process and the effectiveness of the design practices used. Scores will also reflect the effectiveness of the report and presentation in communicating the design process and solution. Design teams must address each of the specified topics in order to receive a score for that topic. Design scoring for all vehicles shall be as follows:

Subject Area	Maximum Points
General	5
Design	15
Analysis	30
Testing	25
Safety	25
Aesthetics	10
Presentation	10
Total	120

N. *Design Score Penalties*

In addition to those previously described, penalties may be imposed by the Judging Team for failures to comply with the rules of the Design Event. Penalties will be assessed according to the following table in cases where an unfair advantage might have been gained or the Judges' ability to evaluate a design has been compromised.

Rules Infraction	Maximum Penalty
Report content largely non-original	Event Disqualification
Late report submittal	4% per day
Late for Static Judging or Safety Check	10%
Late submittal of safety video	0.5% per day (Maximum of 12.5%)
Safety video over 2 minute time limit	5%
Over Page Limit ("non-participant" at 20 pgs over)	3% Per Page
Report does not conform to required outline	10%
Report Cover Page & Vehicle Description Form missing from 1 st page or incomplete	5%
Presentation over time limit	10%

O. *Overall Design Scoring*

The judges will compile the design scores including any penalties on a total points basis. The event score is calculated by:

$$\text{Points} = \frac{\text{Team Design Score}}{\text{Max Possible Design Score}} \times \text{Max Event Points}$$

Where the Maximum Possible Design Score is the maximum points possible according to the Judge's Score Sheet, and the Maximum Event Points are given.

VII. Drag Event

A. Objective

To provide teams the opportunity to demonstrate the speed and reliability of their vehicles in a tournament format.

B. Description

The Drag Event is a head-to-head, tournament-style race where two vehicles compete at a time from a standing start to be the first to cross the finish line.

The event consists of two phases: qualifying and a double-elimination tournament drag race. All vehicles shall compete in the qualifying race. The vehicles with the fastest qualifying times shall compete in the drag tournament.

To win the heat, the driver and the vehicle must cross the finish line.

During the event, **no assistance may be given to the driver(s) of any HPV.**

C. Duration and Timing

Every effort will be made to run the event as quickly as possible. This includes starting sequential heats as soon as the course is clear and lining up upcoming competing pairs of teams as early as possible. An exception will be made for teams that need to race back-to-back during the quarterfinals or semifinals. If a team needs to race back to back a 5 minute maximum rest period will be granted between the end of the previous race and the beginning of the following heat.

D. Drag Course Description

The drag race course shall consist of a paved and near-level course of at least 200m and typically between 300 to 450 meters (984.3 to 1476.4 ft) in length. The course shall be at least 6 meters (19.7 ft) wide at all locations. The surface shall be smooth and free of potholes, cracks, and debris. Curves are permitted on the course, which may be a closed loop (although a closed loop is not required).

The course immediately following the start and immediately preceding the finish line shall be straight, unless separate and equal-length lanes are provided for each vehicle. If the course is not a closed loop there shall be a return path to the staging area.

The course may either be one shared course for both teams or a mirrored "rally track" style course where teams will turn in opposite mirrored directions. A head-to-head finish will still be prioritized with this configuration, but teams may diverge during the race with each team limited to their individual path. Each path will be as close to an exact mirror as possible with the layout, number of turns, turn radius, etc. being exactly the same. Where possible, the number of cones, signage, and other details will also be mirrored exactly.

E. Timing Area

The timing and scoring area shall be off-limits to competitors, spectators, and all others except competition officials and the event timing staff.

F. *Live Standings*

If the race venue can support it, race results shall be posted online. Results should be updated after each individual race, and should indicate the winners' and losers' brackets and race times.

G. *Drivers' Meeting*

All drivers who will participate in the Drag Event must attend the mandatory drivers' meeting for that event. The drivers' meeting shall take place approximately 45 minutes prior to the scheduled start of the race. The meeting will clarify operating procedures and signals and will identify course features, hazards, and landmarks.

Any team that is not represented at this meeting will normally not be permitted to participate in the event; in cases of unavoidable absence, the team may file an appeal with the competition judges, whose decision regarding participation will be final.

H. *Qualifying Race*

The qualifying race place is based on finish times and teams will race in order of vehicle number. The maximum number of vehicles racing in each heat shall be at the discretion of the Head Judge and will depend on the nature of the course and the available timing equipment. Each vehicle shall be timed separately. There may not be a qualifying race if there are fewer than 16 participating teams for the event.

I. *Brackets and Seeding*

The top 16 vehicles from the qualifying race will advance to the elimination rounds. If there are fewer than 16 vehicles, then the tournament shall consist of fewer than 16 vehicles.

After the first round of eliminations, the event is split into two brackets: the winner's bracket and the loser's bracket. At the end of each round, the losers in the winner's bracket move into the loser's bracket. The losers of the loser's bracket are eliminated from the competition. The championship race determines the winner of the event. In the event that neither championship contestant has two losses after the round, an extra race will determine the winner.

Seeding shall be based on qualifying time. That is, the first race shall take place between the vehicles with the first and last qualifying times, the second race between the second and next to last qualifying places, and so on.

Tournament seeding and sequencing may be modified by the Head Judge to account for event-specific circumstances.

J. *Drag Race*

All races in the drag tournament shall be between two vehicles. The preferred racing lane will be given to the vehicle with the better seed position (faster qualifying time).

Vehicles will be instructed at the starting line of the race by a flag person. When both competitors indicate they are ready the flag person will start the race by waving the flag. No verbal commands are required therefore the drivers must be able to clearly see the flag person. If a verbal command is given, it has no bearing on the race start. Only the waving of the flag should start the race. There will be a finish line judge (if not a closed loop) who will determine the winner of the race.

If a competitor moves before the flag is waved, the start line flag judge will call a false start. Teams will be allowed one (1) false start, which will result in a verbal warning and a rerun of the same heat. Subsequent false starts will result in disqualification for the rest of that gender's tournament.

Following the completion of the race competitors must return to the staging area for succeeding elimination rounds. Once there teams will be instructed by the staging area coordinator.

Event and race sequencing will be determined by the Head Judge and announced at the drivers' meeting.

Disabled vehicles at the start or during the race will have no more than 20 seconds to make repairs or they will forfeit the race. Disabled vehicles must clear the course as rapidly as possible.

K. *Race Forfeiture*

Vehicles must be in line and ready to start in turn. If a vehicle is not ready to start at their turn, they forfeit the race and either move to the loser's bracket or are eliminated from the race. If a vehicle is unable to start within 20 seconds of the start signal it must forfeit the race. Forfeiture in the qualifying race makes the vehicle ineligible to compete in the drag tournament.

L. *Start Assistance*

Assistance is not permitted. The driver must be completely self-sufficient from the beginning of the heat until the vehicle crosses the finish line. As always, assistance is permitted in the event of an emergency, but once assistance is given the run is forfeit.

M. *Interruption and Termination*

The Drag Event will normally run continuously. However, circumstances such as equipment failures, an emergency, hazardous weather, or wind conditions may require a delay. Delays or terminations will be determined by the Head Judge with the help of the competition judges.

N. *Scoring*

Scores for teams eliminated in the tournament shall be determined by the round in which the vehicle was eliminated. The place order for all remaining vehicles shall be determined by qualifying speed.

Scoring for teams that qualify in the tournament depends on the round in which they are eliminated from the tournament. See the table below for the example score breakdown for the tournament. If a race results in a no-win situation, both the teams are eliminated in that round and shall be awarded the same losers points. In the resulting races of the no-win race, the opponent scores an automatic win upon crossing the finish line. If this situation occurs for the final race then the race shall happen again to determine the winner. If both the vehicles are unable to compete then the team from winners' bracket is the winner.

Table 1: Drag Tournament Scoring for 16 Teams

	Elimination Match							
Eliminated in Round:	Champion	31 or 30	29	28	26 25	24 23	20 19 18 17	12 11 10 9
Place	1	2	3	4	5	7	9	13
Points	12.5	11.6	10.8	9.9	9.1	8.2	7.4	6.5

$$Points\ per\ place = \frac{Score_{Max} - Score_{Min}}{\#\ of\ places} = \frac{12.5 - 6.5}{7} = \frac{6}{7} = 0.857$$

Table 2: Drag Tournament Scoring for 8 Teams

	Elimination Match					
Eliminated in Round:	Champion	15 14	13	12	10 9	6 5
Place	1	2	3	4	5	7
Points	12.5	11.3	10.1	8.9	7.7	6.5

$$Points\ per\ place = \frac{Score_{Max} - Score_{Min}}{\#\ of\ places} = \frac{12.5 - 6.5}{5} = \frac{6}{5} = 1.2$$

Teams that do not qualify for the tournament will be scored based on time obtained in the qualifying round, in accordance with the following formula:

$$Points = \frac{t_{Fastest\ non-qualifying\ time}}{t} \times (6\ points)$$

O. Fouls and Penalties

Fouls and penalties for the Drag event are described in the general fouls and penalties section of these rules.

P. Score Improvement for Non-qualified Teams

At any event by judges' discretion, the teams that did qualify for the tournament may be allowed to run the course one more time to set a faster time to improve their score for the event. But any team that did not qualify for the tournament shall not be awarded more than 6.0 points.

VIII. Endurance Event

A. Objective

To provide teams with the ability to demonstrate the functionality, agility, utility, and durability of their vehicles.

B. Description

The Endurance Event is a 2.5 hour, timed relay race with multiple laps around a closed course. Each team shall include multiple drivers.

C. Electric Power Requirements

- Electric power equipment as presented during the safety inspection is required to be installed on every vehicle during the Endurance Event
- Teams may only use one traction battery for the entire event
- Batteries can be removed from the vehicle after the first lap
- Batteries can be precharged at the start of the event and can be recharged at any point during the event
- Replacing the traction battery with another one during an event is prohibited

D. Endurance Course

The event shall take place on a closed-loop course approximately 2km in length to the extent that the event site permits but no shorter than 1km.

- The course shall be continuously paved with occasional patches of rough pavement or gravel typical of a public roadway.
- The course shall include turns in both directions and straight sections designed to demonstrate the advantage of the vehicles' aerodynamic features.

E. Start

The start of the race will be an unassisted LeMans style start

- (a) Start Area: The start area shall accommodate a LeMans style start that includes a broad, straight section immediately preceding the start line. This area shall be wide enough to ensure a safe start. The start area will include a designated driver start area at least ten meters away from the vehicles parked in preparation for the start.
- (b) Start Process: Start of the Endurance Event shall begin with all vehicles parked diagonally on one or both sides of the race course. Drivers will be positioned at least ten meters from their vehicle with a parcel of items positioned in front of the driver or adjacent to the vehicle. At the start signal, all drivers shall pick up the parcel, run to their vehicles, enter and buckle in, and then take off.
- (c) Cargo: Start will include the pick-up and stowage of a parcel that must be carried until the first stop.
- (d) Starting Order: Vehicles shall start the endurance race in the order of highest to lowest design score. Tied scores will be ordered by vehicle number. Vehicles without a design score shall be placed at the end of the starting line-up in order of vehicle number.
- (e) Mechanical Malfunctions at Start: Any vehicle that requires mechanical assistance at the time of the start must forfeit its starting position and safely exit to the side of the course; it may rejoin the event at the rear of the field of competitors when ready. Repair work that interferes with the safe and orderly start of an event may result in a penalty against the responsible team.

F. Pits

The pits are a physical space to work on vehicles during the entire event. Teams should bring chairs, sun covering, tools, etc. The pit will include safe entry and exit and a straight run of at least 100 meters when possible between the starting line and the first turn.

- Pit Location: The pit area shall be located in an area adjacent to the course and shall begin not less than 30 meters and not more than 50 meters after the finish line. The pit area shall be located after, but in relatively close proximity to the start line.
- Pit Crews: Due to space limitations, no more than eight crew members (excluding drivers) will be allowed in the pit area for each team. Crew members may not be in another team's pit area without permission.
- Pit Stalls: Prior to the drivers' meeting, teams shall locate their pit stall. All equipment must be placed in the selected pit area prior to the drivers' meeting. During the race, all work in the pit area must take place within the selected pit stall and not in the pit lane. A typical pit stall is 2.6m x 4.9m in dimensions, but may vary as venues allow. (Failure to observe this rule will result in black flag penalties as described in VII Q.)
- Right of Way in the Pit Area: Competing vehicles have the right of way on the course and in the pit areas at all times during an event. Vehicles entering the pit area from the course shall have the right-of way over those returning from the pits to the course. Interfering with a competing vehicle in any way may result in a penalty assessment against the responsible team.

G. Start Assistance

No assistance shall be provided to any driver except in the pit area (except in emergencies). This includes, but is not limited to, picking up or launching a fallen vehicle, helping to steady a vehicle, giving water to a driver, picking up dropped parcel items, etc. The penalty for receiving assistance will be 500 meters deducted from the total race distance for each occurrence.

In the event that assistance is provided to a vehicle after a fall or accident, if the condition of the driver is questionable a judge or course marshal may hold the vehicle for 60 seconds in lieu of the 500 meter penalty. During the 60 second wait, the judge or marshal shall ascertain that the driver is mentally and physically prepared to continue the race.

Note: This rule does not prohibit team members or spectators from checking on the condition of the rider after an accident. If necessary, assistance may be provided to extract an injured or disabled driver or move a disabled vehicle off the course, but may be subject to the 60 second vehicle hold or 500m penalty.

H. General Obstacles

Course obstacles shall include:

1. A speed bump typical of a city street speed control device; speed bumps added to the course will have maximum height no more than 5cm (1.97"), but speed bumps of typical size already present on the course (e.g. permanent asphalt speed bump) may go over this specification.
2. A stop sign, requiring a vehicle to come to a complete stop until signaled to proceed by the stop sign judge.

3. A tight hairpin turn of approximately 180 degrees with a maximum radius that does not exceed 8m (26.2ft). Double hairpin turns are acceptable and encouraged if facilities permit.
4. A slalom section consisting of a series of tight turns as shown in Figure 2. Knocking a tennis ball off of a cone constitutes failure of the obstacle.
 - a. Passing is permitted in the slalom, but due to increased safety concerns (e.g. potential for instability, tight spaces, tight turns, etc.) passing must be done with the utmost caution and will be penalized heavily if an unsafe pass is made. Teams must make certain that there is clear room to pass and also alert the team being passed with the use of a horn or bell.
5. A section of rumble strip which will simulate a washboard road or cobblestone street. This will likely be constructed of 1.9cm x 8.9cm (1x4") boards lying flat running perpendicular to the track on 66cm (26") centers and will be wide enough for two lanes of traffic through the obstacle.

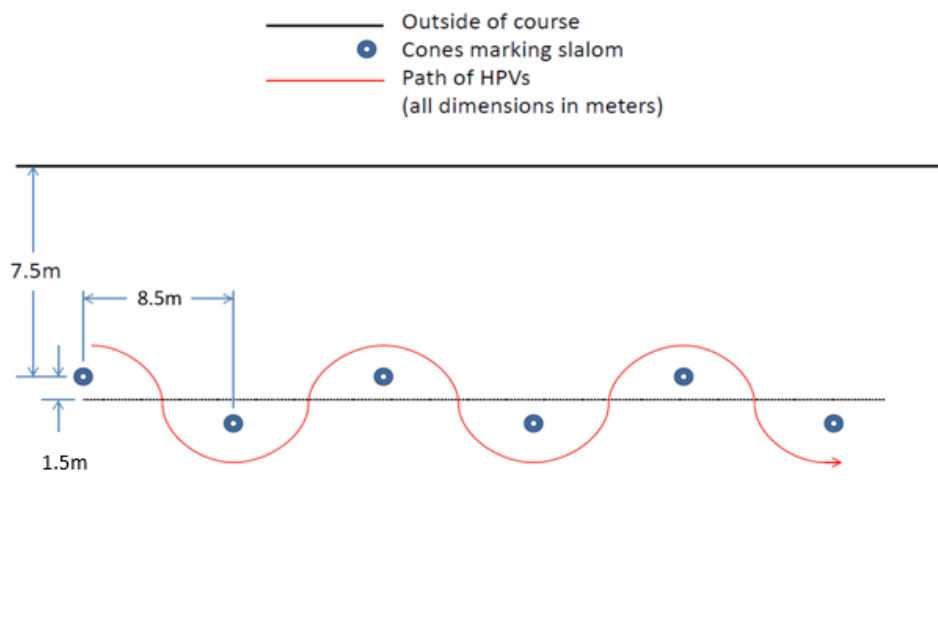

Figure 2: Slalom course (Note: actual layout subject to limitations of venue)

If possible, all obstacles shall be located on the course such that at least one continuous kilometer is obstacle-free, but obstacles will be spread out enough to reduce traffic in and around obstacles if possible. Please note that actual obstacles used at the competitions may differ from described above due to venue limitations.

1. Venue Specific Challenges

Additional challenges and obstacles may be implemented at specific venues to challenge teams to develop further in the areas of practicality and robustness. Each host, in conjunction with the ASME judging staff, will select which specific challenges will be implemented; one to three venue specific challenges will be chosen for each e-HPVC. Some challenges will not be announced until as late as the drivers' meeting immediately before the race, but other challenges, which require substantial design accommodations, will be announced well ahead of time to allow for adequate preparation.

1) *Hill Climb- Low Grade (<5%)*

A low grade hill climbing challenge will be included as a portion of the full endurance lap and teams must complete the obstacle on every lap. Teams will be notified of the hill and approximate grade during the drivers' meeting.

2) *Hill Climb- Steep Grade (≥5%)*

A steeper grade hill climbing challenge will be an independent obstacle from a standard endurance lap. On a lap where a team elects to perform a hill climb challenge; teams will proceed around the course as usual until they approach the entrance to the hill climb obstacle. Teams will then enter the approach chute, gradually slow to a stop at the hill climb start line and then proceed up the incline. Teams will continue upwards, reach the apex indicated by a marker, descend in a slow and controlled manner (walking speed), and finally come to a complete stop at the base of the hill before rejoining the course.

Teams must complete one hill climb for every five total completed laps (rounding down). Only one hill climb may be completed per lap, but hill climb laps may be completed back to back, or spread out at team's discretion. For each team at least two different riders must complete a hill climb challenge.

Teams that cannot climb the incline in the traditional manner in which they operate their vehicle may push their vehicle up the hill, assuming that they follow all other competition rules to complete the challenge. No outside assistance is allowed in making upward or downward progress on the hill.

Teams will be notified of the Steep Hill Climb challenge and approximate grade no later than 90 days prior to the event.

3) *Low Light Endurance Challenge*

The endurance race may be held in the evening or early morning at such a time that natural light is limited or nonexistent. Depending on the venue, artificial lighting such as street lights may or may not be present. This challenge is specifically intended to emphasize the lighting and visibility design needs for practical human powered transportation.

- This is a strictly additive challenge and all other rules and challenges of the endurance event are still valid
- All vehicles will be required to run a 300 lumen or greater white headlight and a 10 lumen or greater red taillight
- Safety judging will include special emphasis on lighting and visibility. Failure to meet safety, visibility, or lighting requirements during safety judging will disqualify a team from the low light endurance event.
- Vehicles may be pulled from the event if for any reason they are deemed unsafe for the low light conditions. This includes the loss of a headlight or taillight.
- The low light endurance challenge will be announced no later than 90 days prior to the event

4) *Parcel Pickup and Delivery*

A parcel pickup and delivery station shall be provided on the course. Each team is required to deliver or pick up a parcel five times during the race. At least two drivers must make a pickup or delivery. Teams start the race with a parcel. At the first parcel stop, the initial parcel is deposited with a parcel clerk who will record the time and vehicle number. Subsequently, parcels are alternatively picked up or dropped off. After dropping the parcel on the fifth stop, the parcel pickup/delivery requirement will be met. Teams may choose when to stop, and stops are permitted throughout the event. Note that delays due to a waiting queue are possible. Teams are encouraged to plan stops accordingly. Failure to complete five stops with at least two drivers shall result in a one lap penalty for each missed stop. If all five stops are made by the same driver the team will be penalized one lap. Damage to parcels will be assessed at the completion of the five drop offs and appropriate penalties will be made at that time (See IX).

When entering the parcel pickup area, vehicles must park in designated parking spots. These spots will be oriented perpendicular to the direction of the course. Drivers must fully dismount their vehicle, retrieve and secure the parcel, and re-mount their vehicle. The orientation of the parking spot will require vehicles to either back into or out of the spot. Note that, as always during the endurance race, drivers are allowed to push their vehicle. Vehicle entry/exit may not be undertaken in active traffic.

The parcel will be a standard sized 38x33x20 cm (15”h x 13”w x 8”d) reusable grocery bag containing items determined by the host school (mass not to exceed 5.5 kg).

The parcel pickup and delivery challenge will be announced no later than 90 days prior to the event.

5) *Weighted Trailer Challenge*

The trailer challenge will be **an optional challenge** that teams may elect to complete on a single lap of their endurance race. Teams will be required to stop, connect a weighted trailer, and complete a full lap. The bonus assessed will be based on the amount of weight elected to tow.

All teams intending to attempt the weighted trailer challenge must design onto their vehicle a trailer mount ring. The mounting ring shall be mounted horizontally and located at the rearmost location of their vehicle 350mm above the ground. The ring must measure 2 inch ID and 1/4” gauge such as ring 3564T26 offered on McMaster-Carr. The event hosts will provide a trailer that attaches to the trailer mounting ring. The unloaded trailer will have a mass of approximately 11.5kg (25.4lbm) and teams can elect to add up to 45.2kg (100lbm) in increments of 11.3kg (25lbm).

If a team decides to complete the weighted trailer pull lap they will proceed around the course as usual until reaching the trailer installation area. Teams will enter the queue, decelerate, and stop at the line specified on the ground. The vehicle operator will then exit the vehicle, indicate to the judges how much desired additional weight will be added, retrieve the weighted trailer and attach it to their vehicle to be towed around the following lap. Upon successfully hitching their vehicle to the trailer, operators can ingress

and proceed around the lap as normal. After completion of the single lap and arrival at the trailer installation area, drivers will exit the vehicle, unhitch the trailer and place it back in its station. The driver can then ingress and rejoin the race as normal. If teams cannot complete the weighted lap they are responsible to return the trailer to the trailer installation area as quickly as possible by any means possible; this includes the aid of additional team members. Teams that attempt the challenge, but do not return the trailer in a reasonable time (approximately three times an average lap time) will be penalized.

Once teams successfully return with the weighted trailer the judges will determine the appropriate bonus. Bonus reward laps will be added on to each team's total distance at the end of the race and be calculated as follows:

$$\text{Rewarded Additional Laps} = 2 * \frac{\text{total weight of trailer towed (kg)}}{\text{maximum weight of trailer}}$$

$$\text{maximum weight of trailer} = \text{weight of unloaded trailer} + 45.2(\text{kg})$$

Only a limited number of teams will be able to perform the weighted trailer challenge at a time, therefore, delays due to a waiting queue are possible. Teams are encouraged to plan their attempt accordingly.

The weighted trailer challenge will be announced no later than 90 days prior to the event

6) *Bypass Challenge*

The bypass challenge is an **optional challenge** that teams can complete during each lap. No points are awarded for completing this obstacle, but if completed it may reduce lap time. The bypass challenge allows bypassing a section of the course (~10% - 25% of course length) by traversing an especially challenging obstacle(s). Obstacles could include, for example, loose terrain (sand, gravel, mud, uneven terrain, etc) or steep slopes (curbs, drop-offs, potholes, etc).

Teams must approach and exit the obstacle at a safe speed and yield to both vehicles currently attempting the challenge and oncoming vehicles when re-entering the course.

Teams that cannot complete the Bypass Challenge in the usual manner in which they operate their vehicle may push their vehicle, assuming that they follow all other competition rules to complete the challenge. No outside assistance is allowed.

The endurance bypass challenge will be announced no later than 90 days prior to the event.

J. Lap Counting Process

Laps will be counted by the competition judges and an Assistant Lap Counter provided by each team.

- The Judging Team will record laps of all teams in sequence as the official record of the race.
- Assistant Lap Counters: Each competing team must provide one assistant lap counter as a scoring assistant to count and record laps. This record will serve as a backup to correlate the official lap count. Lap counters will be provided with a lap counting sheet to record:
 - The time of day each lap is completed using time from their own watch; counters need not be synchronized between teams and/or judges
 - The times of driver changes
 - Any other substantive data

No score will be tabulated for any team that does not provide an assistant lap counter.

K. Driver/Stoker Requirements

- (a) Minimum distance for any driver: the number of laps nearest 5 km or 30 minutes (whichever occurs first).
- (b) Maximum distance for any driver: the number of laps nearest 20 km.
- (c) A team may include any number of drivers as long as the distance-per-driver requirements are met.
- (d) All laps by an individual driver must be continuous – that is, all drivers must complete their laps in sequence, uninterrupted by any other driver, and may not ride in that event further.
- (e) A driver's distance or time may be cut short due to injury, vehicle disablement, or end of scheduled race time. There will be no penalty as a result of the scheduled race ending prior to the present occupant's completion of the minimum distance. Otherwise, the Head Judge must rule that the driver is indeed unable to continue in order to avoid penalty.
- (f) All laps not completed to these requirements will be subject to the lap requirement violation penalty

L. Judging Area

The lap counting and judging area will be adjacent to the start/finish area. It will be off-limits to everyone except competition officials and the assistant lap counters.

M. Drivers' Meeting

All drivers who will participate in the Endurance Event must attend the mandatory Drivers' Meeting for that event. Drivers' meetings will take place approximately 45 minutes prior to the scheduled start of the race. The meeting will clarify operating procedures and signals and will identify course features, hazards, and landmarks.

Any team that is not represented at this meeting will normally not be permitted to participate in the event; in cases of unavoidable absence, the team may file an appeal with the Judging Team, whose decision regarding participation will be final.

N. Course Practice

The road course will be opened by the Head Judge for practice and will remain open at their sole discretion. All vehicles practicing on the course must be operated in the intended direction of the course and in a safe manner and with extreme caution, particularly when entering the pit area or any other areas congested with participants, officials, or spectators.

All drivers operating a vehicle on or adjacent to the course, on competing vehicles or otherwise must wear helmets meeting the approved standards for the competition.

O. Signals

Flags will be used by competition officials as follows:

Flag Color	Usage
Green	Start event
Red	Stop event
Yellow or Orange	Proceed with caution, beware of hazards, no passing without sufficient passing lane
Black	Proceed directly to pits: problem with vehicle, rule infringement, or penalty assessment
White	Less than 10 minutes remaining in the race
Black & White Checkered	Event completed, proceed to pit area

Each Course Marshal will be supplied with a yellow flag with which to signal caution in the event of an accident. During a yellow caution flag, passing will be allowed when sufficient space is available to pass, but under no circumstances will unsportsmanlike conduct, cutting off another vehicle, or contacting another vehicle be permitted, and violating this rule will result in a conduct violation.

All other flags will be held in the judging area. As described, a green flag will signal that the event is underway, the black flag is used to indicate that a vehicle is to go directly to the pits on their next lap, the white flag indicates 10 minutes left in race time, and the checkered flag indicates the end of the race. A red flag displayed at the race start will indicate that a restart is necessary, and all vehicles should proceed by their most direct path to the starting area. A red flag during the event requires that all vehicles stop at the earliest safe opportunity. At the end of the race, a 'clean up vehicle' will display a red flag to indicate that the race has ended and is not to be overtaken. The vehicles should then return to the pit area as the course will then be closed.

P. Disabled Vehicles

The first concern following any accident is the safety of the driver. Once it has been determined that the driver is not injured, disabled vehicles must be removed from the course as soon as possible. In the event of an injury, no person should take any action that might increase the risk associated with the injury. In the case of injury, only on-site paramedics, ambulance workers, or licensed medical professionals should tend to the injured.

Disabled vehicles must be removed from the course at the nearest safe exit; drivers may not move disabled vehicles along the course other than to reach a point of removal. Disabled

vehicles may be returned to the pit area by the driver and/or team members by safely removing the vehicle from the course and wheeling or carrying it to the pit area.

Course workers will assist with the removal of vehicles from the course, as necessary in the interest of safety. The primary responsibility, however, remains with the respective team. Non-emergency blockage of the course by a disabled vehicle may result in the assessment of a penalty.

Traffic will be controlled in the area of a disabled vehicle by the Course Marshals or by other competition officials, who will oversee the clearing of the course and signal the resumption of normal competition.

Disabled vehicles that have been removed from the course and repaired must re-enter the course either at the point of removal or at some point that it had passed between that point and the starting line on that same lap. That is, no vehicle will advance its position on the course as the result of a disablement. Re-entering vehicles must yield the right-of-way to vehicles on the course.

Q. Fouls and Penalties

Fouls and penalties for the endurance event are described in the general fouls and penalties section.

R. Interruptions

The Endurance Event will normally run continuously. However, obstruction of the course, an emergency, hazardous weather, or other conditions may require a delay or premature termination of the event. The need for and extent of any such delay or termination will be evaluated by the Judging Team, with the Head Judge making the final determination.

If the event is interrupted and a restart is required, the restart order will recreate, as nearly as possible, the order of vehicles at the time of the interruption.

S. Termination

The endurance event shall be run for 2.5 hours. At that time, all vehicles still in the competition will be permitted to finish the lap they are currently on. A "sweep" vehicle will enter the course and complete one lap. The sweep vehicle shall not pass any operable competing vehicles on the course, nor shall any competing vehicles pass the sweep vehicle. At the completion of the lap by the sweep vehicle, the event will be declared complete.

When the official race clock reads elapsed time of 2:20, the white flag shall be placed on prominent display near the judge's area, and will remain there until a race time of 2:30. At that time, the white flag shall be replaced with the black and white checkered flag.

T. Scoring

Vehicle rank in the endurance event is based on average speed minus penalties. The formula for average speed is:

$$V_{average} = \frac{(Number\ of\ Laps\ Completed - Lap\ Penalties) \times (Lap\ Length) - (Distance\ Penalties)}{(Finish\ Time + Time\ Penalties)}$$

Points are awarded based on each individual vehicle's average speed compared to the fastest average speed.

$$Points = \frac{V_{average}}{V_{maximum\ average}} \times Maximum\ Event\ Points$$

Where the Maximum Event Points is the point value for the event, specified in Section IX.

IX. General Fouls and Penalties

Throughout the competition the Head Judge and the competition judges will determine whether a foul has occurred and the extent of any assessed penalty (which may include disqualification from an event or from the competition). The responsible team will be notified as soon as possible of an infraction and any resultant penalty by the competition judges. Penalty appeals may be filed in accordance with specified protest procedures.

Penalties (including but not limited to examples below) will be assessed as follows:

A. *Equipment violations*

- Penalty: Require a pit stop to remedy the violation
- Example: Failure to meet equipment requirements, including the proper display of vehicle numbers

B. *Safety violations*

- Penalty:
 - Drag: Require a pit stop to remedy the violation and up to 5% penalty in final event score
 - Endurance: Require a pit stop to remedy the violation and subtraction of one or more laps from the team's total lap count
- Example: Such as entering the course without a proper helmet or seat belt

C. *Drag Event false start penalty*

- Penalty: A verbal warning is issued for the first false of the team. A penalty of disqualification is assessed for the subsequent false start.

D. *Lap requirement violations*

- Penalty: Deduction of one lap for each improper lap
- Example:
 - Failure to meet minimum or maximum driver lap requirements
 - For each lap missed, one lap will be subtracted from the total number completed

E. *Illegal start assistance on course*

- Penalties:
 - Drag: Up to 25% penalty in final event score
 - Endurance: Deduction of 500 meters from total distance

F. *Conduct violations*

- Penalties:
 - Drag: Up to 25% penalty in final event score
 - Endurance:
 - First violation: A minimum of a 15-second delay in the pit area. No work may be performed and no driver changes may be made during this stop.
 - Second violation: A minimum of a 60-second delay, with the same stipulations as above.
 - Third violation: Disqualification from the event

- Examples of conduct violations include but are not limited to:
 - Obstruction of a vehicle by a competing team or by a spectator
 - Foul driving, whether intentional or unintentional
 - Including an unsuccessful or dangerous pass in the slalom
 - Poor sportsmanship or an activity that fosters unfair competition

G. Failure to complete an obstacle

- Penalty: Deduction of $\frac{1}{3}$ lap from total distance per infraction OR repeat the failed obstacle
- Example: Failure to stop at stop sign, complete the slalom, hairpin turn, quick turn, improper entry or exit of HPV at parcel stop, knocking any tennis balls off of cones, etc.

H. Damaging or loss of parcel

- Penalty: Deduction of a maximum of 1,500 meters from total distance depending on severity of damage.

I. Drafting

- Drafting is permitted as long as there is no interference with other vehicles.

X. Overall Scoring

Overall Score Scores from all events will be combined to determine the overall standing of the competition.

The formula for combining the scores is:

$$\text{Overall Score} = \sum \text{Event Scores}$$

The maximum event points are:

Competition Event	Maximum Points
Design Event	50
Drag Event	25
Endurance Event	25
Total Score	100

In the case of a tie in the overall point count, the order of finish in the Design Event will determine the overall finish for all vehicles.

XI. Announcement of Results and Awards

A. Announcement of Results

The judges will post the results of each event of the competition as soon as possible after the completion of the respective event and validation of the collected data.

B. Presentation of Awards

The awards presentation will be held after the completion of the competition's final event.

C. Competition Awards

Competition awards shall be given as follows

Overall 1st Place:	Trophy and cash prize
Overall 2nd Place:	Trophy and cash prize
Overall 3rd Place:	Trophy and cash prize
Design Event:	1st + cash prize/trophy, 2nd and 3rd place trophies
Drag Event:	1st + cash prize/trophy, 2nd and 3rd place trophies
Endurance Event:	1st + cash prize/trophy, 2nd and 3rd place trophies
Best Innovation:	Trophy and cash prize

Cash prize amounts will be posted on the Efx websites.

Overall winner must participate, complete minimum requirements, and score points in all events to be eligible for monetary awards. Minimum requirements are valid non-zero scores in all events.

D. Other Awards

Judges may recognize significant achievements by one or more teams during the course of the Competition. Other awards may include but are not limited to the following:

- Sportsmanship
- Team Spirit
- Best Rookie Team
- Special Achievement
- Perseverance
- Craftsmanship

Additional awards may be suggested or provided by the judges, host, the teams involved, or others. Such awards are encouraged in the spirit of the competition; however, all such awards must be approved by the competition judges.

E. Review and Modification of Results

If an error or discrepancy is determined in the final results, it will be addressed by the competition judges as quickly as possible. To assure scoring accuracy is maintained, the competition judges will expedite every effort to resolve errors and reserves the right to review

the results for up to 48 hours after the official awards ceremony to ensure all scores are accurate and final.

XII. Clarification and Modification of Rules

A. Clarification and Modification of the Rules

These rules may be modified by the Competition Judges as necessary to maintain the competition as a challenging and rewarding experience for engineering students. No changes by any party shall be made without the written consent of the Global Chief Judge. Questions or recommended changes should be referred to the Global Chief Judge.

B. Questions and Comments About the Rules

Questions and comments about the rules must be posted on the e-HPVC forum here:

<https://groups.google.com/g/asme-hpvc>

XIII. Appendix 1 Design Event Score Sheet

General	5	Evaluated based on report
Form 6	1	Form 6 completed and attached to the front of the report
Title Page	1	Title page information correct and complete
3-View Drawing	1	3-View drawing, in accordance with ASME Y14.5 and related standards such as ASME Y14.24 and ASME Y14.3
Abstract	2	Abstract included, correct length, clear, concise, and informative. This should be page 1
Design	15	Evaluated based on report
New Design	2	2 - Teams must demonstrate that the entry is a new design (not just a new frame or fairing) completed during the current academic year, or not HPVC entry for last 2 years 1 - Some new elements (frame, fairing, etc.) or no HPVC entry for last year 0 - Similar to previous year's entry
Design Methodology		
Design Objectives	1	Clearly state the objectives and design mission of the vehicle
Background research	1	Include supporting research and review of prior art.
Prior Work	1	Clearly document any design, fabrication, or testing that was not completed in the current academic year.
Organizational Timeline	1	Include an organizational timeline or Gantt chart showing project scheduling and completion.
Design Criteria	1	Provide well established design criteria and product design specifications
Alternatives and Evaluation	2	Present alternative designs that were considered using concept improvement and selection techniques
Structured Design Methods	1	Document use of established design methodologies
Description	1	Describe the final vehicle design, making generous use of drawings and figures.
Innovation	0	Describe aspects of the vehicle design that are particularly innovative (if any).
Discretionary Points	4	Discretionary points based on overall thoroughness, quality, accuracy, and approach

Analysis	30	Evaluated based on report
Rollover/Side Protection System		Per RPS requirements
Top Load Modeling	1	Clearly and accurately describe constraints, idealizations, load path from rider to ground, etc.
Top Load Results	2	Clearly describe and interpret results, score depends on results and perceived validity of results. Target load is to be applied and the deflection value is to be clearly documented as result. 0: Maximum total elastic deflection equal to or greater than 7.6 cm (3.0 in); 1: 6.4 cm (2.5 in); 2: 5.1 cm (2.0 in) or less
Side Load Modeling	1	Clearly and accurately describe constraints, idealizations, load path from rider to ground, etc.
Side Load Results	2	Clearly describe and interpret results, score depends on results and perceived validity of results. Target load is to be applied and deflection value is to be clearly documented as result. 0: Maximum total elastic deflection equal to or greater than 6.4 cm (2.5 in); 1: 5.1 cm (2.0 in); 2: 3.8 cm (1.5 in) or less
Structural Analytical Calculations		Demonstrated appropriate and correct use of numerical computational tools such as FEA, CFD, etc.
Objectives	1	Clear objective for the analysis
Analysis Case Definitions	1	Clearly identify and describe analysis cases, include rationale for each
Modeling	1	Clearly and accurately describe constraints, idealizations, use of symmetry, etc.
Results	2	Clearly describe and interpret results
Design Modifications	1	Demonstrate how results were used to modify and improve the design
Aerodynamics		
Aero Device Incorporated	1	All entries are required to have an aerodynamic device incorporated into their design (makeshift items, false claims, and claims such as reclined rider position contributes to aero will not be granted credit)
Alternatives Evaluated	1	Must evaluate several alternatives in a trade study
Chosen Design Substantiated	1	Must substantiate chosen aero device through analysis
Electrical Analysis		
	5	Document electrical analyses, including analysis of provided safety features (such as external emergency shutdown mechanism), impact on performance and usage of hybrid vehicle as a means of transport.
Other Analyses		Vehicle handling, stability, steering, suspension kinematics & dynamics, optimizations, and other analyses
Objectives	1	Clear objective for the analysis
Analysis Case Definitions	1	Clearly identify and describe analysis cases, include rationale for each
Results	1	Clearly describe and interpret results
Design Modifications	1	Demonstrate how results were used to modify and improve the design
Discretionary Points	6	Discretionary points based on overall thoroughness, quality, accuracy, and approach

Testing	25	Evaluated based on report and presentation
Rollover/Side Protection System		Per RPS requirements
Top Load Testing Setup	1	Test method clearly described, appropriate, and scientific
Top Load Testing Results	2	Clearly describe and interpret results, score depends on results and perceived validity of results. Increasing load is to be added to RPS until maximum deflection is reached and then load achieved is to be clearly stated as the result. 0: Less than 1780N (400 lbf); 1: 1780-2670N (400-599 lbf); 2: ≥2670N (600 lbf)
Side Load Testing Setup	1	Test method clearly described, appropriate, and scientific
Side Load Testing Results	2	Clearly describe and interpret results, score depends on results and perceived validity of results. Increasing load is to be added to RPS until maximum deflection is reached and then load achieved is to be clearly stated as the result. 0: Less than 890N (200 lbf); 1: 890-1330N (200-299 lbf); 2: >1330N (300 lbf)
Developmental Testing		Physical testing to develop or verify design, usually conducted prior to final vehicle construction
Objective & Methodology	1	Clear objective for the experiment. Methodology clearly described, appropriate, and scientific
Results and Discussion	1	Data is reported and presented clearly, with appropriate discussion (interpretation, error sources, uncertainty, etc.)
Statistical Analysis	1	Data is analyzed and presented clearly, with appropriate statistical analyses (t-test, ANOVA, regression, etc.) and measures (mean and standard deviation, confidence intervals, p-value, etc.)
Conclusions	1	Conclusions and recommendations stated clearly. Results should be quantitative where possible and include applicable statistical analyses (mean, standard deviation, student T test, etc.)
Design Modifications	1	Demonstrate how testing results used to modify or improve the design
Comparison with PDS and Analysis	1	Test results clearly compared with analysis results and product design specifications
Comprehensiveness	1	Extent of developmental testing: 0: few experiments/little significance on design, 1: many experiments/significant effect on design
Performance Testing		Physical testing (often conducted on final vehicle) to evaluate and optimize performance
Objective & Methodology	1	Clear objective for the experiment. Methodology clearly described, appropriate, and scientific.
Results and Discussion	1	Data is reported and presented clearly, with appropriate discussion (interpretation, error sources, uncertainty, etc.)
Statistical Analysis	1	Data is analyzed and presented clearly, with appropriate statistical analyses (t-test, ANOVA, regression, etc.) and measures (mean and standard deviation, confidence intervals, p-value, etc.)
Conclusions	1	Conclusions and recommendations stated clearly. Results should be quantitative where possible and include applicable statistical analyses (mean, standard deviation, student T test, etc.)
Design Modifications	1	Demonstrate how testing results used to modify or improve the design
Comparison with PDS and Analysis	1	Test results clearly compared with analysis results and product design specifications
Comprehensiveness	1	Extent of developmental testing: 0: few experiments/little significance on design, 1: many experiments/significant effect on design
Discretionary Points	5	Discretionary points based on overall thoroughness, quality, accuracy, and approach

Safety	25	Evaluated based on safety inspection and safety video
Rollover/Side Protection System		
Installation & Design	1.5	Rollover/Side protection system installed and functional
Consistent with RPS rule	1.5	RPS design and fabrication appears consistent with rules
Prevents bodily contact with ground	1	RPS must prevent the riders appendages and head from contacting the ground in the event of a crash where the HPVC falls over or inverts
Safety Harness	2	Seat belt installed correctly and appears to meet rules
Steering System	1.5	No excessive play or looseness, correct installation, apparent stability, etc.
Braking System	1.5	Inspection shows brake levers & calipers/brake assemblies are rigidly mounted, cables are tight, pads have ample thickness and pads make full contact with rim/disk. HPV must pass braking performance test within one or two attempts for full points
Sharp Edges, Protrusions, Pinch Points	2	No sharp edges or protrusions on fairing, frame or components. No hazardous pinch points, especially near spoked wheels, chains, sprockets, etc. (Subtract points for serious hazards)
Electrical Safety	5	Electrical equipment used must be properly fused, electrical cables must be in good condition, electrical related components must be securely mounted, battery must be isolated from the rider using a rigid bulkhead, etc.
Other Hazards	1	No other obvious hazards
Rider's Field of View	1	Rider should have more than 180 degrees of visibility
Safety Accessories		
Bell/Horn	1	Audible signal device installed and operational
Taillight	1	Red Taillight visible 150 meters to the rear, installed and operational
Headlight	0.5	White headlight installed and operational, visible 150 meters to the front, installed and operational
Side reflectors	0.5	Red, amber, or similar colored reflectors on each side of vehicle properly installed
Rear view mirrors	0.5	Mirror(s) installed providing the driver with views to the rear of the vehicle
Additional Safety Features	1.5	An additional safety feature(s) are incorporated specific to their design (beyond required safety features) [Based on safety video]
Discretionary Points	2	Discretionary points based on the quality and thoroughness of design to maximize HPVC safety [Based on safety video and inspection]

Aesthetics	10	Evaluated based on state of vehicle at safety inspection
Overall impression of vehicle	3	Overall impression
Quality of craftsmanship	3	Craftsmanship (welds, joints, assembly, etc.) is professional and attractive
Quality of custom parts	2	Team-fabricated and custom parts look professional and of high quality
Quality of Frame/Fairing Finish	2	Exterior finish and decoration quality is neat, attractive, and professional (frame and/or fairing)
Presentation	10	Evaluated based on Presentation
Organization	2	Information is presented clearly in a logical sequence which can be easily followed
Content	2	Presentation contains accurate and original information with sufficient evidence to support the claims
Creativity	2	Demonstrate creativity through usage of visual aids and presentation of material in interesting/unique ways
Speaking Skills	2	Demonstrates confidence through clear articulation, rhythm and tone without reading the slides
Subject Knowledge	2	Presenter demonstrates full knowledge and can answer and elaborate on most/all questions

XIV. Appendix 2: Protest Form

	<p>PROTESTS Form e-Human Powered Vehicle Challenge Competition Location: _____ Competition Date: _____</p>
<p>*** This is <u>NOT</u> a required form. It may be used <u>only if</u> a team is filing a protest during a competition *** Additional details can be found in the Rules, Section III.G. ***</p>	

Protests

Protests may be made in accordance with the rules of the ASME e-Human Powered Vehicle Challenge. This protest format may be used or not used at the discretion of the team or individual presenting the protest. If this format is not used, the information outlined herein should be included in whatever format is used.

Any intent to protest must be announced within 15 minutes of the causative action, and the written protest must be submitted within 30 minutes of this announcement. Oral protests will not be honored.

Date: _____ Protestor’s Vehicle No: _____

Protesting School: _____

Other Vehicle(s) Involved (if applies): _____

Event during which protested action occurred: _____

Nature of protest (e.g., rule violation, error in scoring, etc.): _____

Description of incident/statement of protest (may be entered or continued on separate page)

Judges Action: _____

XVI. Appendix 4: Report Cover Page & Vehicle Description Form

	<p>Report Cover Page & Vehicle Description Form e-Human Powered Vehicle Challenge Competition Location: _____ Competition Date: _____</p>
<p>This required document for all teams is to be incorporated in to your Design Report. Please Observe Your Due Dates; see the ASME e-HPVC website and rules for due dates.</p>	

Vehicle Description

University name:

Vehicle name:

Vehicle number:

Vehicle configuration:

Upright _____

Semi-recumbent _____

Prone _____

Other (specify) _____

Frame material: _____

Fairing material(s): _____

Number of wheels: _____

Vehicle Dimensions (m)

Length: _____

Width: _____

Height: _____

Wheelbase: _____

Weight Distribution (kg)

Front: _____

Rear: _____

Total Weight (kg): _____

Wheel Size (m)

Front: _____

Rear: _____

Frontal area (m²): _____

Steering (Front or Rear)

Braking (Front, Rear, or Both): _____

Estimated Coefficient of Drag: _____

Vehicle history (e.g., has it competed before? where? when?):

XVII. Appendix 5: Endurance Event Lap Count Sheet

University:						
Vehicle Number:						
Lap	Time of Day	Driver	—	Lap	Time of Day	Driver
0				36		
1				37		
2				38		
3				39		
4				40		
5				41		
6				42		
7				43		
8				44		
9				45		
10				46		
11				47		
12				48		
13				49		
14				50		
15				51		
16				52		
17				53		
18				54		
19				55		
20				56		
21				57		
22				58		
23				59		
24				60		
25				61		
26				62		
27				63		
28				64		
29				65		
30				66		
31				67		
32				68		
33				69		
34				70		
35				71		

Attention: Time is to be recorded as local time of day and not as race time
 The minimum number of laps/time for each driver is 2 laps or 30 mins, whichever comes first
 The maximum number of laps for any driver will be announced during the drivers' meeting